

**MSAGX75F60A**

**Features**

- Rugged polysilicon gate cell structure
- high current handling capability, latch-proof
- Hermetically sealed, surface mount power package
- Low package inductance
- Very low thermal resistance
- Reverse polarity available upon request
- high frequency IGBT, low switching losses

**600 Volts**  
**75 Amps**  
**2.7 Volts vce(sat)**

**N-CHANNEL**  
**INSULATED GATE**  
**BIPOLAR TRANSISTOR**

**Maximum Ratings @ 25C (unless otherwise specified)**

DESCRIPTION	SYMBOL	MAX.	UNIT
Collector-to-Emitter Breakdown Voltage (Gate Shorted to Emitter) @ $T_J \geq 25^\circ\text{C}$	$BV_{CES}$	600	Volts
Collector-to-Gate Breakdown Voltage @ $T_J \geq 25^\circ\text{C}$ , $R_{GS} = 1\text{ M}\Omega$	$BV_{CGR}$	600	Volts
Continuous Gate-to-Emitter Voltage	$V_{GES}$	+/-20	Volts
Transient Gate-to-Emitter Voltage	$V_{GEM}$	+/-30	Volts
Continuous Collector Current $T_J = 25^\circ\text{C}$	$I_{C25}$	75	Amps
$90^\circ\text{C}$	$I_{C90}$	50	
Peak Collector Current, pulse width limited by $T_{Jmax}$	$I_{CM}$	200	Amps
Safe Operating Area (RBSOA) @ $V_{GE} = 15\text{V}$ , $L = 30\mu\text{H}$ (clamped inductive load), $R_G = 2.7\Omega$ , $T_J = 125^\circ\text{C}$ , $V_{CE} = 0.8 \times V_{CES}$	$I_{max}$	100	Amps
Power Dissipation	$P_D$	300	Watts
Junction Temperature Range	$T_J$	-55 to +150	$^\circ\text{C}$
Storage Temperature Range	$T_{stg}$	-55 to +150	$^\circ\text{C}$
Continuous Source Current (Body Diode)	$I_S$	24	Amps
Pulse Source Current (Body Diode)	$I_{SM}$	96	Amps
Thermal Resistance, Junction to Case	$\theta_{JC}$	0.25	$^\circ\text{C/W}$

**Mechanical Outline**

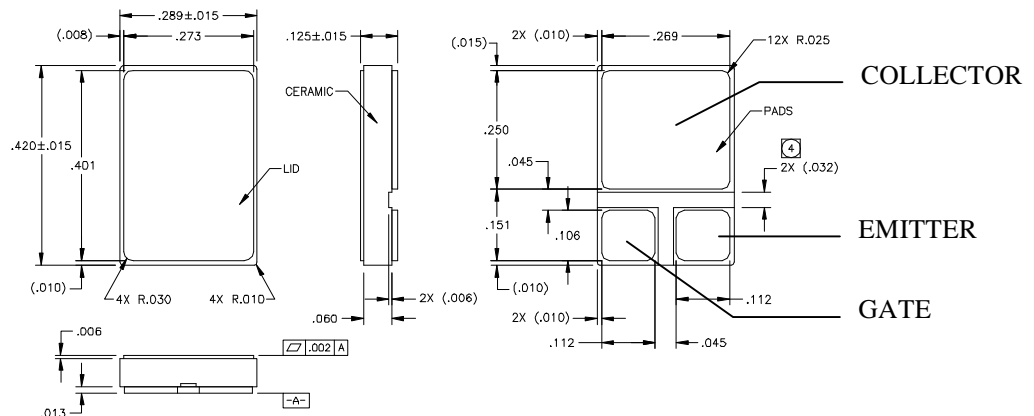

## Electrical Parameters @ 25C (unless otherwise specified)

DESCRIPTION	SYMBOL	CONDITIONS	MIN	TYP.	MAX	UNIT
Collector-to-Emitter Breakdown Voltage (Gate Shorted to Emitter)	$BV_{CES}$	$V_{GS} = 0\text{ V}, I_C = 250\ \mu\text{A}$	600			V
Gate Threshold Voltage	$V_{GE(th)}$	$V_{CE} = V_{GE}, I_C = 250\ \mu\text{A}$	2.5		5.0	V
Gate-to-Emitter Leakage Current	$I_{GES}$	$V_{GE} = \pm 20V_{DC}, V_{CE} = 0$ $T_J = 25^\circ\text{C}$ $T_J = 125^\circ\text{C}$			$\pm 100$ $\pm 200$	nA
Collector-to-Emitter Leakage Current (Zero Gate Voltage Collector Current)	$I_{CES}$	$V_{CE} = 0.8 \cdot BV_{CES}$ $V_{GE} = 0\text{ V}$ $T_J = 25^\circ\text{C}$ $T_J = 125^\circ\text{C}$			200 1000	$\mu\text{A}$
Collector-to-Emitter Saturation Voltage (1)	$V_{CE(sat)}$	$V_{GE} = 15\text{ V}, I_C = 50\text{ A}$ $I_C = 50\text{ A}$ $T_J = 25^\circ\text{C}$ $T_J = 125^\circ\text{C}$		2.5	2.7	V
Forward Transconductance (1)	$g_{fs}$	$V_{CE} \geq 10\text{ V}; I_C = 50\text{ A}$	25	35		S
Input Capacitance	$C_{ies}$	$V_{GE} = 0\text{ V}, V_{CE} = 25\text{ V}, f = 1\text{ MHz}$		4000		pF
Output Capacitance	$C_{oes}$			340		
Reverse Transfer Capacitance	$C_{res}$			100		
<b>INDUCTIVE LOAD, <math>T_J = 25^\circ\text{C}</math></b>						
Turn-on Delay Time	$t_{d(on)}$	$V_{GE} = 15\text{ V}, V_{CE} = 480\text{ V},$ $I_C = 50\text{ A}, R_G = 2.7\ \Omega,$ $L = 100\ \mu\text{H}$ note 2, 3		50		ns
Rise Time	$t_{ri}$			210		ns
Turn-off Delay Time	$t_{d(off)}$			200		ns
Fall Time	$t_{fi}$			275	400	ns
Off Energy	$E_{off}$			4.8		mJ
<b>INDUCTIVE LOAD, <math>T_J = 125^\circ\text{C}</math></b>						
Turn-on Delay Time	$t_{d(on)}$	$V_{GE} = 15\text{ V}, V_{CE} = 480\text{ V},$ $I_C = 50\text{ A}, R_G = 2.7\ \Omega,$ $L = 100\ \mu\text{H}$ note 2, 3		50		ns
Rise Time	$t_{ri}$			240		ns
On Energy	$E_{on}$			3		mJ
Turn-off Delay Time	$t_{d(off)}$			280		ns
Fall Time	$t_{fi}$			600		ns
Off Energy	$E_{off}$		9.6		mJ	
Total Gate Charge	$Q_g$	$V_{GE} = 15\text{ V}, V_{CE} = 300\text{ V}, I_C = 50\text{ A}$		200	250	nC
Gate-to-Emitter Charge	$Q_{ge}$			35	50	
Gate-to-Collector (Miller) Charge	$Q_{gc}$			80	100	

### Notes

- (1) Pulse test,  $t \leq 300\ \mu\text{s}$ , duty cycle  $\delta \leq 2\%$
- (2) switching times and losses may increase for larger  $\delta$  and/or  $R_G$  values or higher junction temperatures.
- (3) switching losses include "tail" losses
- (4) Microsemi Corp. does not manufacture this die; contact company for details.